



Air Mizer[®]
COMPLETE SHAFT SEALS

THE COMPLETE SEALING SOLUTION

LOSING MORE THAN PRODUCT

Product handling applications like mixers, blenders, agitators and extruders often suffer from product leakage due to unreliable sealing. In these applications, product migrates down the shaft, through the sealing device to atmosphere. Lost product leads to higher production costs, increased maintenance, environmental concerns and unsafe working conditions.

The bottom line...product loss is more than just lost product.



Product loss leads to higher production costs, increased maintenance, downtime, and environmental concerns.

THE HIGH COST OF CONTACT SEALS

Conventional contact sealing methods, such as mechanical packing, mechanical seals, and lip seals, are found in a wide variety of process applications. All of these methods rely on dynamic mechanical contact to create a seal. Shaft movement and misalignment challenge contact sealing methods due to their rigid designs.

While contact seals may work well initially, over time they either wear out or groove the shaft at the point of contact; once this happens, the seal will begin to leak and need to be replaced. The short and unpredictable service life of contact seals makes them inadequate methods of reliably sealing against product loss.

SHAFT SEALING TECHNOLOGIES					
	AM SOLUTIONS	SPRING SEALS	MECHANICAL SEALS	MECHANICAL PACKING	LIP SEALS
Non-Contact Seal	✓	✓			
Seals Powders	✓	✓		✓	
Seals Liquids	✓	✓	✓	✓	✓
Seals Bulk Solids	✓	✓		✓	
Accommodates Angular Misalignment	✓				
Accommodates Radial Run-Out	✓	✓			
Accommodates Axial Movement	✓				
Maintenance Free	✓				
Custom Engineered	✓	✓	✓		
Proven 5 Year+ Life Expectancy	✓				

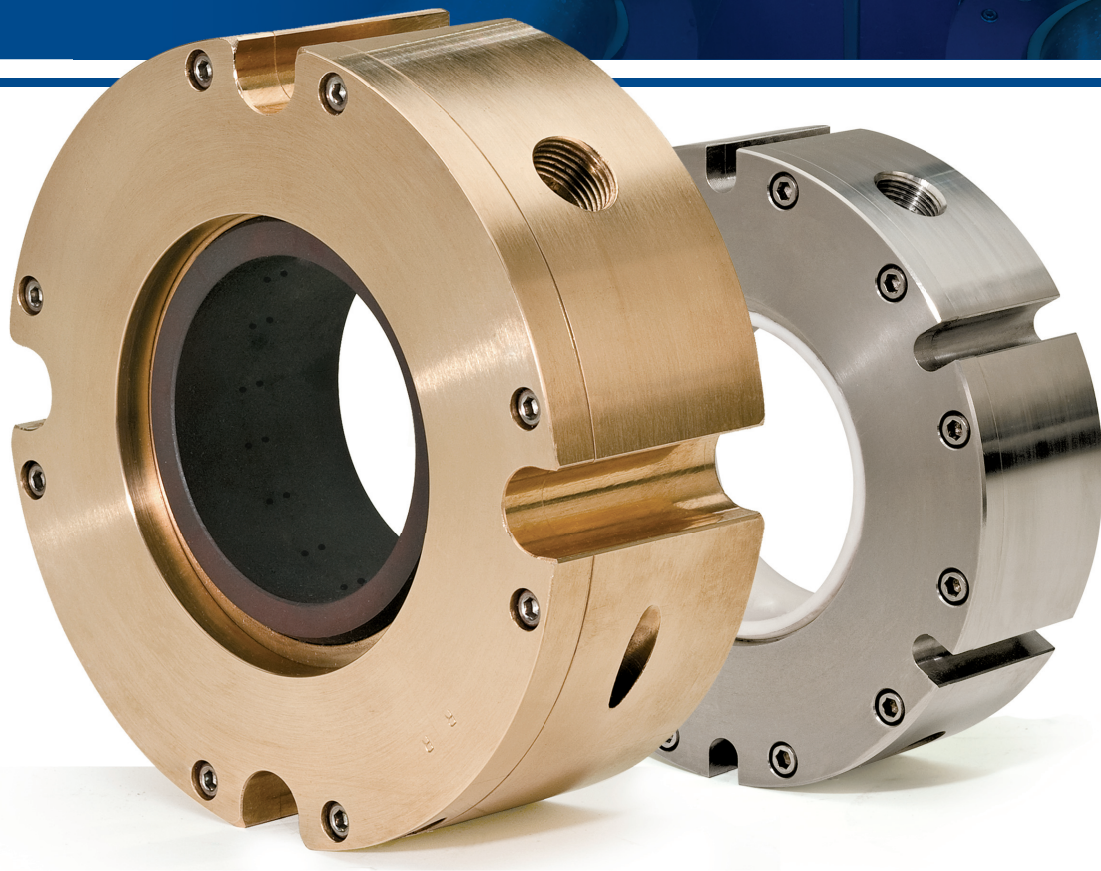

AIR MIZER SHAFT SEALS FROM INPRO/SEAL

The Inpro/Seal® Air Mizer® is a permanent shaft seal for powders, liquids, slurries, and bulk solids on product applications across a variety of industries. Their patented technology creates an effective seal by utilizing a positive purge along the shaft— preventing product from escaping into atmosphere and contamination from entering the process.

The Air Mizer's non-wearing design is maintenance free and constructed to last the lifetime of your equipment. Unlike conventional contact seals, Air Mizer shaft seals can fully articulate to accommodate radial run-out, axial movement, and angular misalignment simultaneously.

Inpro/Seal Air Mizer shaft seals incorporate a variety of design features to fit your specific applications and operating environments, including AM Smooth Bore, AM Food Grade and AM Rotor.



Air Mizer shaft seals are custom engineered to fit the exact requirements of your equipment and operating environment.

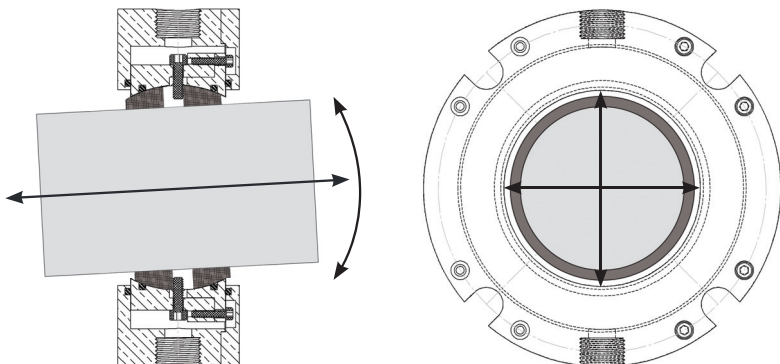

Inpro/Seal AM Solutions are designed to handle extreme conditions including radial run-out, axial movement and angular misalignment.

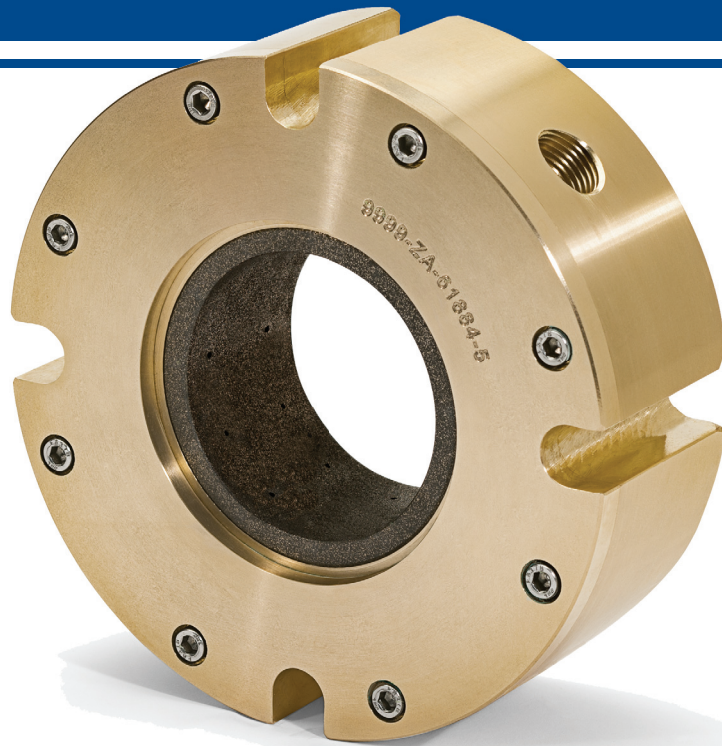

AM Smooth Bore

The AM Smooth Bore Air Mizer® design is the standard for product applications in general processing industries.

The AM Smooth Bore utilizes the Opti-Mizer™ throttle to create a positive purge along the shaft that permanently eliminates product loss and contamination. The Opti-Mizer throttle directs small amounts of air, or inert gas, through a precision clearance, pressurizing the area between the throttle and shaft to form a non-contacting seal. The sealing medium is evenly dispersed to maintain concentricity between the shaft and throttle for optimum equipment reliability.

Designed to last the lifetime of your equipment, the AM Smooth Bore is maintenance free with no wearing parts. Its patented throttle/stator interface fully articulates to accommodate radial run-out, axial movement, and angular misalignment simultaneously.

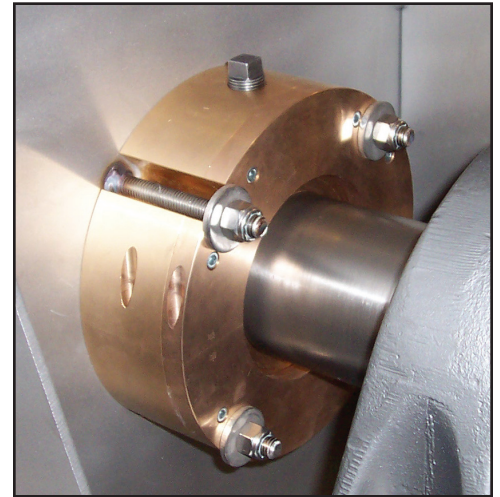

The AM Smooth Bore Air Mizer shaft seal permanently eliminates product loss and contamination on processing applications.

AM Smooth Bore Designs

AM Smooth Bore- standard design for general processing applications and environments

AM Smooth Bore DS- installed on applications with a tight clearance between multiple shafts

AM Smooth Bore ATEX- ATEX certified design for applications in explosive environments

AM Smooth Bore HT- utilizes special materials to accommodate temperatures exceeding 232°C [450°F]

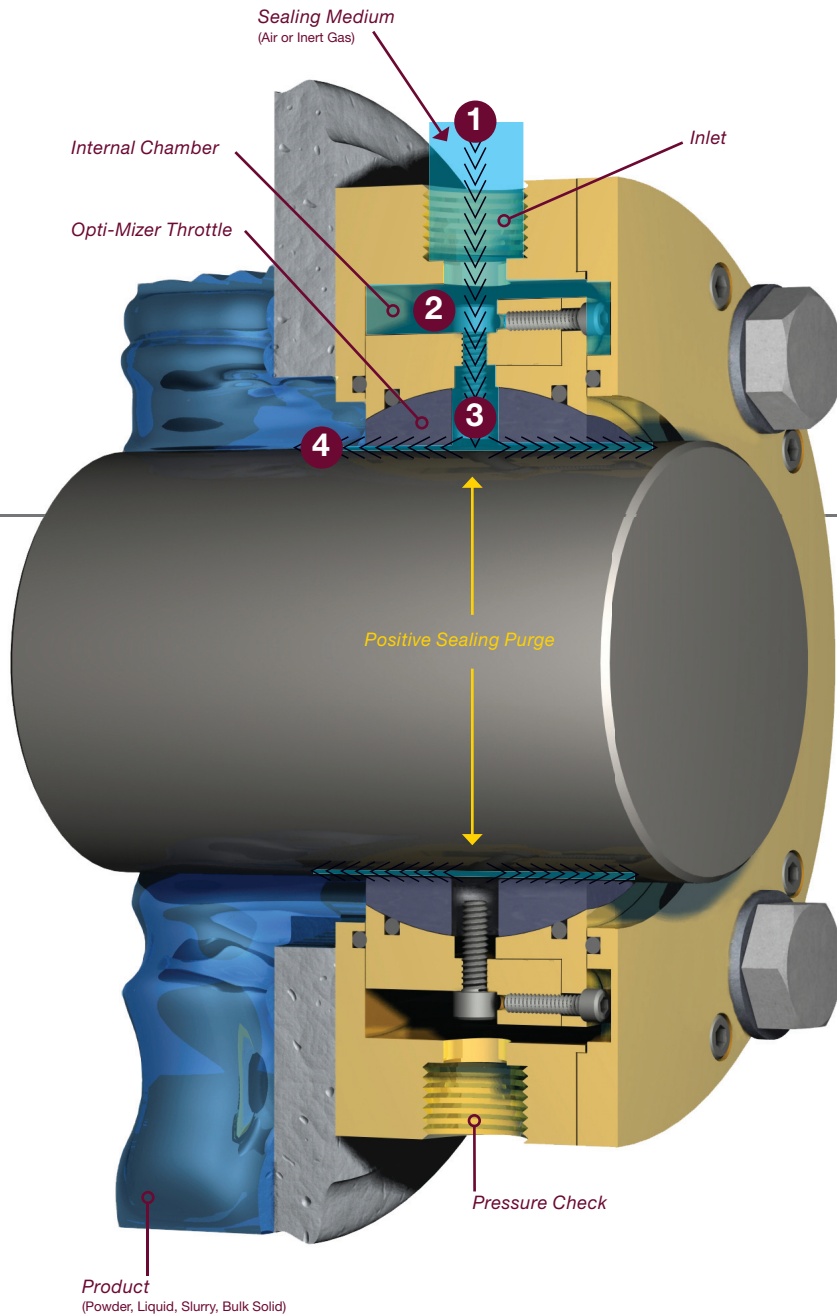

AM Smooth Bore: How It Works

1. Air, or inert gas, enters the AM Smooth Bore through the inlet and into the internal chamber.
2. Air is pressurized in the internal chamber and directed towards the Opti-Mizer throttle.
3. The Opti-Mizer throttle's unique design efficiently distributes the air evenly around the circumference of the shaft, creating a positive purge.
4. The tight clearance between the Opti-Mizer throttle and shaft achieves a high pressure barrier that prevents product from escaping into atmosphere and keeps contaminants out of the process.



AM Food Grade

The AM Food Grade Air Mizer® design is a permanent shaft seal constructed of FDA approved materials installed on product applications within the food processing industry.

The AM Food Grade seals against product loss and contamination by directing small amounts of air, or inert gas, through a precision clearance between the Opti-Mizer™ throttle and the shaft, pressurizing the clearance. The sealing medium is evenly dispersed to maintain concentricity between the shaft and throttle for optimum equipment reliability. Its unique design is maintenance free with no wearing parts. The patented throttle design fully articulates to accommodate radial run-out, axial movement, and angular misalignment simultaneously.

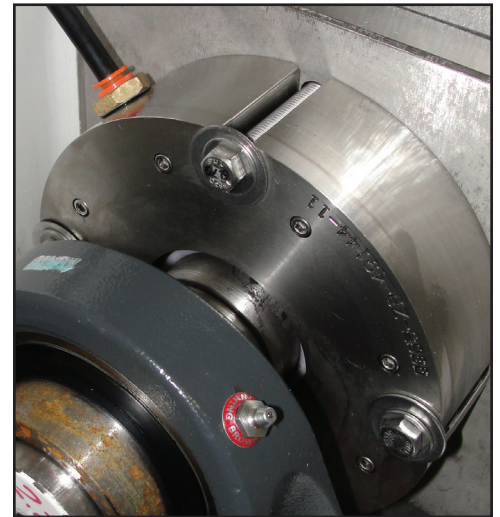

The AM Food Grade is a permanent shaft seal made of food grade materials for applications in the food processing industry.

AM Food Grade Designs

AM Food Grade- standard design constructed of food grade materials for food processing applications and environments

AM Food Grade USDA- constructed of 3A certified materials, meeting USDA construction standards for use specifically in meat, milk, and dairy industries

AM Food Grade DS- installed on applications with a tight clearance between multiple shafts

AM Food Grade ATEX- ATEX certified design for applications in explosive environments like sugar and flour



AM Rotor

The AM Rotor Air Mizer® design is used on applications with no axial movement.

The AM Rotor is a non-contacting shaft seal that permanently protects against product loss and contamination. Its unique design utilizes a throttle that grips the shaft and rotates within the seal. Air, or inert gas, is used to create a positive purge that flows between the throttle and stator, pressurizing the clearance and directing the sealing medium evenly towards the product and atmosphere. The throttle fully articulates to accommodate radial run-out and angular misalignment simultaneously. This design is commonly used on a variety of applications, including screw conveyors and rotary feed valves.



Air Mizer AM CEMA shaft seal installed on a CEMA Screw Conveyor.

AM Rotor Designs

AM Rotor- standard design for applications with no axial movement

AM CEMA- designed for use on CEMA screw conveyors with six standard options that correspond to CEMA size specifications

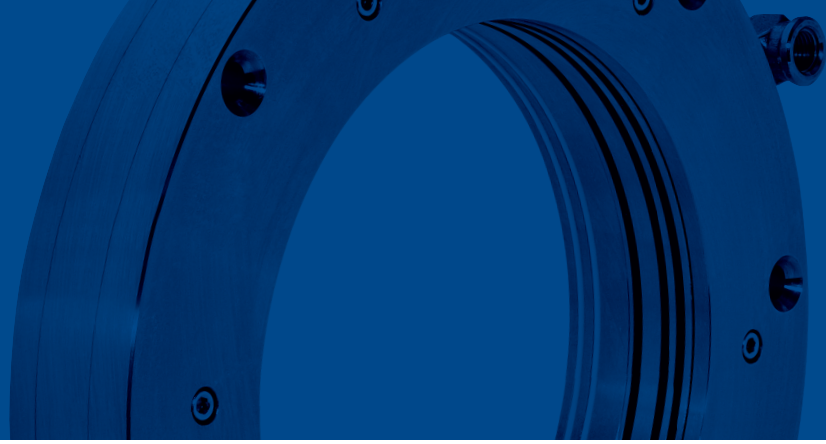

THE INPRO/SEAL ADVANTAGE

GUARANTEED PERFORMANCE

Inpro/Seal® is committed to delivering innovative technology and superior customer support...standard with every solution. Inpro/Seal Air Mizer® shaft seals are backed by a performance guarantee. See our website for complete details.

UNMATCHED CUSTOMER SERVICE

Inpro/Seal's responsive global sales network is committed to making sure you have the right technology for your product applications, right when you need it. No matter the application or operating environment, we can deliver a custom engineered solution designed to meet your specific needs.

EXPERIENCE YOU CAN TRUST

Inpro/Seal, the leader in permanent bearing protection and process seals, has been maximizing uptime on rotating equipment for over 40 years. Our knowledgeable team will help you determine the best Air Mizer shaft seal for your product applications. We've been the trusted source for sealing technology on rotating equipment for more than 40 years and have installed countless complete shaft seals in industries worldwide.

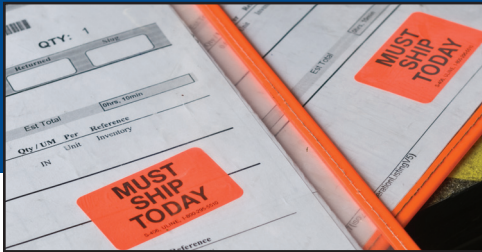

READY TO GET STARTED?

Visit www.inpro-seal.com to contact your local Inpro/Seal representative or submit an inquiry.



INPRO/SEAL®



www.inpro-seal.com | info@inpro-seal.com