

# BEARING ISOLATOR ELIMINATES CLINKER GRINDER MAINTENANCE

MANY COAL-FIRED POWER plants have a continuing problem with premature bearing failures on clinker grinders. As with most coal-fired power plants, Georgia Power uses clinker grinders in its ash handling system to crush large lumps of bottom ash into easily sluiced, smaller sizes. In this process, coal or ash is quenched in wet ash, hydraulically discharged through ash sluice trenches and pumped to an ash fill area.

During the process, large lumps of ash are formed on the boiler walls. Double roll clinker grinders contain "teeth" that work under high pressure to shatter the ash material (clinker) and grind them into smaller sizes. Once ground, this material is sent to an ash pit where it is converted into water slurry and removed through a water channel (sluice) in the basement of the plant.

Georgia Power's problem exists at most coal plants--outdated sealing methods were causing water, fly ash, coal and other materials to leak out and contaminate clinker grinder bearings. The end result was premature and unnecessary bearing failure.

At one point, one of the company's plants was replacing bearings and sprockets in its four clinker grinders about every four months at a cost of \$16,400 per replacement. At this point, Georgia Power contacted Inpro/Seal. Inpro/Seal's bearing isolator is a compound labyrinth sealing device that has long proven itself in process applications worldwide as an extremely effective way to protect bearings.

This particular plant uses four clinker grinders manufactured by Pennsylvania Crusher Co. Each clinker grinder contains two seals. Replacing the bearings and sprockets on the inboard or drive side of four clinker grinders was becoming fairly routine and quite costly. It typically

took two men 20 hours to replace the bearings, costing about \$1,200 per grinder for labor, or \$4,800 for all four grinders. In addition, it cost \$1,200 per grinder to replace the bearings and \$1,200 per grinder to replace the sprockets, adding \$9,600 more to the cost. Another \$500 per grinder was spent to replace the packing, contributing another \$2,000, pushing the total repair cost for all four clinker grinders to \$16,400. Because the grinders had to be repaired every four months, the plant was spending about \$49,200 per year to keep the clinker grinders operating properly.

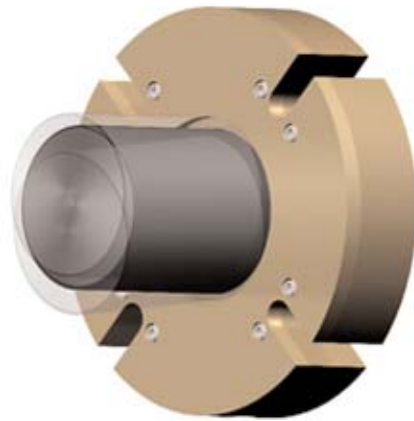

**Inpro/Seal® Air Mizer-PS**

Inpro/Seal's R & D staff developed a solution to this problem--a two plane articulating Air Mizer-PS seal. This seal moves up and down and with angular motions, allowing it to handle all kinds of radial and axial movement. Other features include a non-contact design for longer service life, easy installation and a unique constant air purge system that functions as a barrier to contamination.

The plant installed eight Air Mizer-PS seals costing \$19,600, in all four grinders in January 2005. The grinders haven't failed since. The new Air Mizer-PS seals, therefore, have paid for themselves and saved

Georgia Power an additional \$29,600 in the first year.

This installation was not Georgia Power's first experience with Inpro/Seal's articulating sealing device. A few years earlier, another Georgia Power coal-fired plant was having problems with leaking on two Allen-Sherman-Hoff grinding machines that contain two clinker grinders on each unit, running at 65 rpm.

Plant personnel tried, without success, a number of sealing methods to eliminate the leaking, including lip seals, gasketing, fibrous materials and other packing methods. No matter what they tried, they could not stop the leaking problems and the bearings continued to fail.

In addition, water-ash mixture wound up on the floor under the ash pits. This contributed to additional downtime and more maintenance headaches, along with unnecessary labor, safety and environmental concerns. Before turning to Inpro/Seal, plant personnel assumed there was no way around leaking problems and bearing failure was considered "normal."

Inpro/Seal understood that common sealing methods used by coal plants simply do not protect the grinder bearings. Contact seals and fibrous packing are subject to wear and short operating lifetimes, while simple labyrinth seals allow the free transfer of particulates that progressively deteriorate the immediate environment. In addition, particulates act as a contaminant and grind away at operating equipment, damaging the shaft, seal and other critical components of the clinker grinder.

Since installing the articulating Air Mizer-PS seals, in December 2002, the plant has not experienced a clinker grinder failure.

