



PERMANENT BEARING PROTECTION

Bearing Isolator



INPRO/SEAL[®]

A Waukesha Bearings Business

INCREASE THE RELIABILITY OF YOUR ROTATING EQUIPMENT

The Importance of Bearing Protection

Bearing failure is the leading cause of rotating equipment failure across multiple industries and applications. It leads to expensive unscheduled downtime and lost production.

While there are many factors that contribute to failed bearings, over half of bearing failures are caused by contamination ingress into the bearing housing and lubrication loss.

Manufacturers and users of rotating equipment are placing increased emphasis on bearing protection as a means of improving the overall reliability of their rotating equipment.

The High Cost of Contact Seals

A common method of bearing protection is the contact seal. A contact seal is a bearing seal that uses contact on the shaft to retain lubrication and/or exclude contamination by creating a barrier to the bearing housing. Examples of contact seals are lip seals, mechanical seals and magnetic seals.

All contact seals have a finite life expectancy, eventually wearing at the point of contact or grooving the shaft. As a result, they no longer effectively seal the bearing enclosure. This short and unpredictable service life makes contact seals inadequate. Rotating equipment becomes unreliable, and catastrophic failure due to bearing degradation is common.

To eliminate seal failure and increase equipment reliability, finite-life contact seals need to be replaced with a permanent solution.

LEADING CAUSES OF MOTOR FAILURE

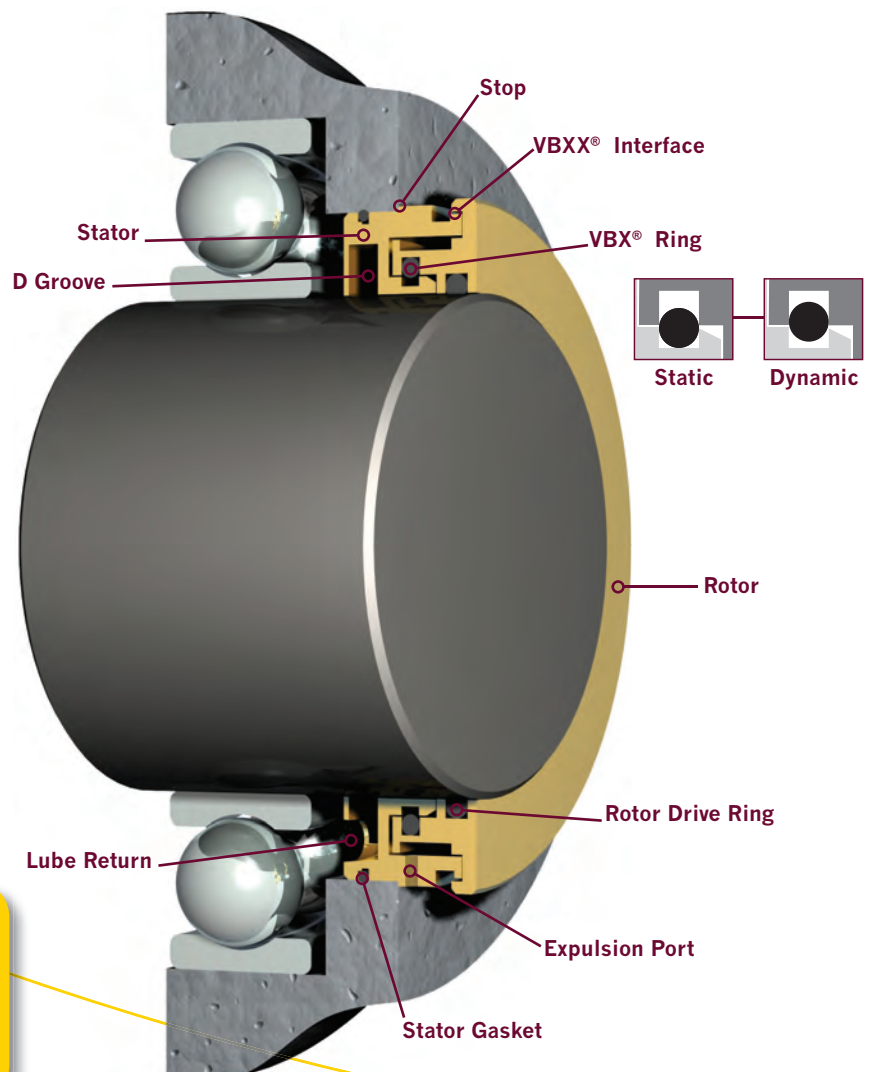
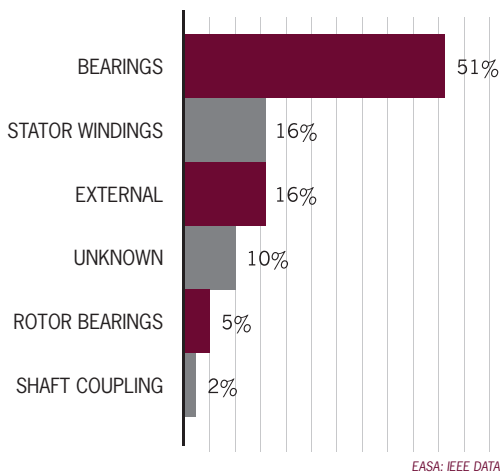

**SAME-DAY
SHIPPING AVAILABLE**

MOTORS



The Inpro/Seal® Solution

As the inventor of the original Bearing Isolator, Inpro/Seal has delivered proven permanent bearing protection for rotating equipment applications for more than 30 years.

The Inpro/Seal Bearing Isolator is a non-contacting, permanent bearing protection device. Inpro/Seal's patented design consists of a unitized stator and rotor that form a compound labyrinth seal with no wearing parts – ensuring permanent protection. The stator is typically pressed into the bearing housing, while the rotor turns with the shaft.

The Inpro/Seal Bearing Isolator protects in multiple ways. Lubricant is captured in the inner portion of the labyrinth and flows back to the bearing housing. Outside contamination attempting to enter the bearing housing is captured in the outer labyrinth paths and expelled through a port in the stator by centrifugal force and gravity.

Inpro/Seal's patented VBX® vapor blocking ring inhibits the free transfer of vapor contamination when the rotating equipment is cycled off.

Benefits:

- Non-wearing, non-contacting, permanent bearing protection
- Patented VBX® ring blocks the transfer of vapor contamination created by heating/cooling of the bearing enclosure
- Split designs available for easy installation
- Can be installed by OEMs or retrofitted on site
- Maintenance free
- Zero energy consumption
- Can accommodate shaft sizes of 1.59 – 121.92 cm. (0.625 – 48.0 in)*
- Standard temperature tolerances range from -37°C (-35°F) – 204°C (400°F)*
- Manufactured in bronze, stainless steel, aluminum or other materials for more extreme conditions

* Utilizing special design and material provisions, products can be manufactured to exceed these ranges.

PUMPS

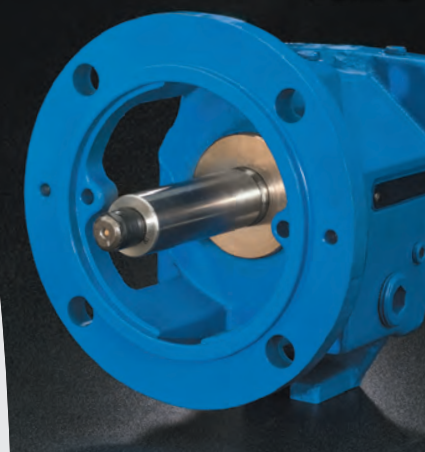

PILLOW BLOCKS



GEARBOXES

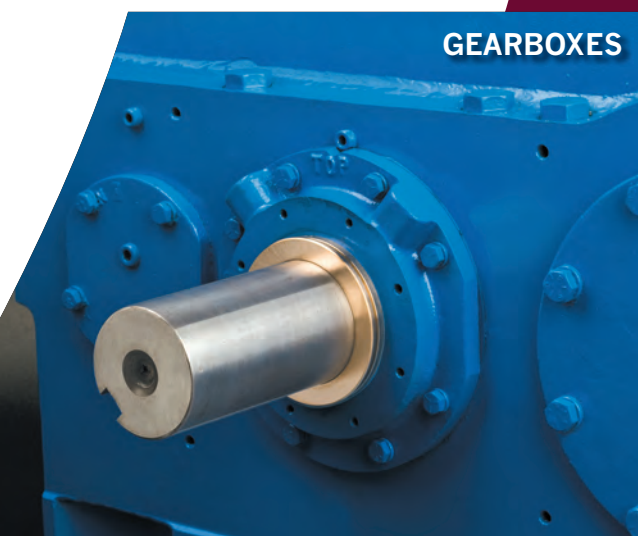

The Inpro/Seal® Bearing Isolator is a non-contacting, non-wearing, permanent bearing protection device.

GUARANTEED PERFORMANCE

The Inpro/Seal® Bearing Isolator is backed by an unconditional performance guarantee. See our website for complete details.

Unmatched Customer Service

Inpro/Seal's responsive global sales network is committed to making sure you have the right technology for your application, right when you need it. We know that time means money for you. That's why we offer same-day shipping on most products, even new designs. No matter what your application, we can deliver a custom engineered solution designed to meet your specific needs.

Technology you can rely on, supported by customer service you'll appreciate.

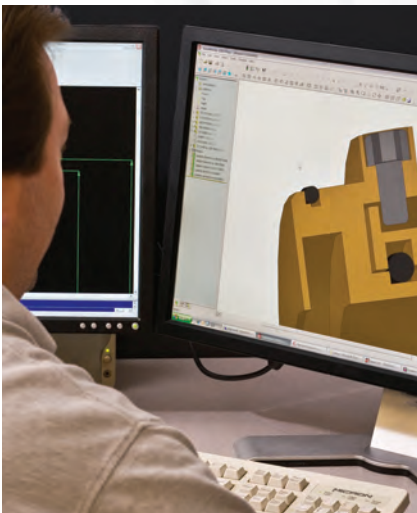

All designs are custom engineered to fit exact requirements.

A Universal Solution

The Inpro/Seal® Bearing Isolator is a unique barrier for contamination ingress and lubrication retention for bearings installed in pumps, motors, gearboxes, pillow blocks, steam turbines, sleeve-bearing motors, paper machine rolls, machine tool spindles and many other types of rotating equipment. This technology has been applied across a variety of industries including chemical processing, food and beverage, mining, oil and gas, power generation, primary metals, processing, and pulp and paper.

No matter the size or complexity of your application, Inpro/Seal can design an isolator to fit your exact specifications.

Experience You Can Trust

Permanent bearing protection requires a custom engineered solution that takes into account all these factors:

- Lubrication type
- Bearing type
- Flooded applications
- Size restrictions
- Operating equipment
- Shaft movement
- RPM
- SFPM

You don't need to be an expert; our knowledgeable team will help. You can count on Inpro/Seal, the leader in bearing and system protection, to maximize the uptime of your rotating equipment. We've been the trusted source for bearing isolator technology for more than 30 years and have installed millions of bearing isolators on multiple applications worldwide.

The Inpro/Seal Advantage

Inpro/Seal is committed to delivering innovative technology and superior customer support...standard with every solution. When you work with Inpro/Seal, you can expect:

- Same-day shipments available on most products, including new designs
- Custom engineered solutions for your application and operating environment
- Knowledgeable sales network providing localized support
- Unconditional performance guarantee – see website for complete details

READY TO GET STARTED?

Visit www.inpro-seal.com to contact your local Inpro/Seal representative or request a quote.

The Inpro/Seal® Bearing Isolator is a custom engineered solution and some designs may be protected by one, more than one or none of the following US and/or foreign patents and/or pending patent applications including US Pat. 7,052,014; 6,419,233; 6,311,984; 6,234,489; 6,182,972; 6,062,568; 5,951,020; 5,865,441; 5,498,006; 5,378,000 and 5,335,921.



www.inpro-seal.com | info@inpro-seal.com | +44 141 424 4122