

INSTALLATION INSTRUCTIONS: SENTINEL™ FLOATING BRUSH SEAL (FBS)

This installation instruction guide is an overview of the handling, installation and placement of Inpro/Seal® Sentinel Floating Brush Seals (FBS) installed on process steam turbines.

HANDLING

Receiving

- Check shipping container for any external damage.
- Confirm brush seals packaging integrity.
- Visually inspect parts:
 - A small “separation” of bristles is not cause for rejection.
 - Verify that no damage to the bristle inner diameter is evident as depicted below:



Damaged Bristles

Acceptable Bristles

- Keep product protected until ready for installation.
- Contact an Inpro/Seal representative if damaged;
 - **do not install in machinery!**
- Keep the original packaging should a return be required.

Bristle Care

- The bristles should not come in contact with anything prior to installation. Do not touch with hand or foreign objects such as rags or tools. Do not store brush seal segment on its inner diameter, or place on a rag or other non-uniform surface.
 - This could cause damage and affect the performance of the product.
- The bristles are small and could cause a puncture.
- Handle by the outer housing only.

INSTALLATION

Special Note: The Sentinel FBS is directionally biased with shaft rotation. Additionally, the brush faces the high pressure side with the carbon element on the low pressure side. Special care must be taken by the installer to ensure rotation and orientation are correct at each seal location.

Bill of Material Inspection

- Match all parts with customer drawings and turbine seal location.

Preparation

- Inspect each outer housing to assure there is no damage.
- Remove any raised surfaces or burrs taking care not to contact the bristle inner diameter.

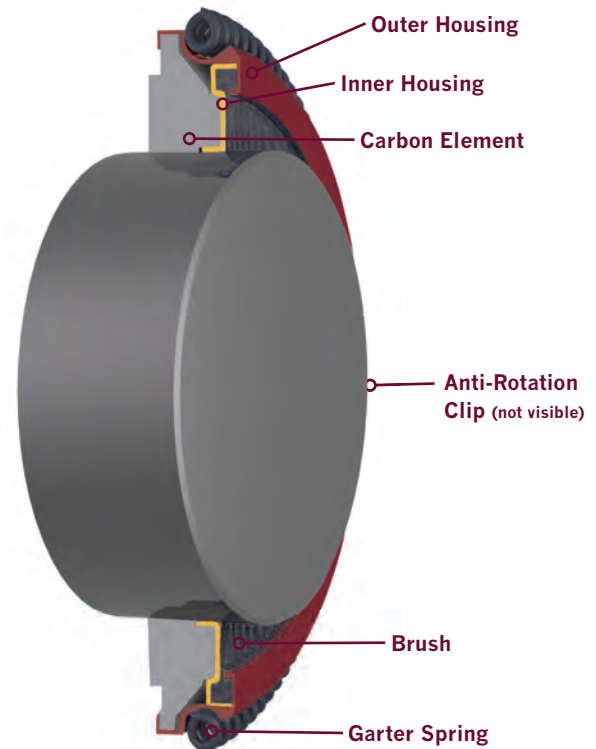

Sentinel FBS

- Clean any residual oil or contaminants taking care not to contact the bristle inner diameter.
- Inspect mating shaft surfaces to assure there are no anomalies or surface finish issues.
 - A surface finish of 32 or better is recommended.
- Review handling instructions.

Brush Location

- Installation location of the brush seals may vary, but the recommended placement of the seals is nearest to the turbine's wheel and in front of the leak off drain slots.
- It is recommended to use enough Carbon seals and brush seals to fill the (packing cases) per the OEM requirements.

Install

- Install Sentinel FBS into gland cavity: see below images for proper pressure and rotation orientation
 - Visually assure rotation direction and seal orientation are correct for each Sentinel FBS at each seal position.
 - If shaft is installed, assure the outer housing/brush segments are "rolled in" with the bristle lay angle.



High Pressure Seal Side (Brush)



Low Pressure Seal Side (Carbon Element)

INITIAL START UP CONSIDERATION

• Brush seals are normally applied with a cold line-to-line or small interference fit to the shaft. Since alignment, run-out, thermal and centrifugal growth may vary; the actual amount of interference may also vary. This variation may cause a temporary increase in localized heat which would increase vibration as one approaches the first critical or operating speed. Should this occur, let the turbine run at the highest acceptable speed to initiate the "wearing-in" of the brush seal bristles. Once the vibrations have subsided, proceed to the desired speed. The duration of the "run-in" period is dependent on many factors and can't be easily predicted; however, it could be many hours depending on the actual conditions. Contact an Inpro/Seal representative if there is a need for further assistance.

